

# 200 Series 2:1

## Air Operated Fluid Pump



Immersed Lower Design

IPM's 200 Series 2:1 is designed specifically for difficult to handle materials. The immersed lower pump, tie-tubes, and quick release bung bushing allow quick drum change without exposing the system to contamination and moisture.

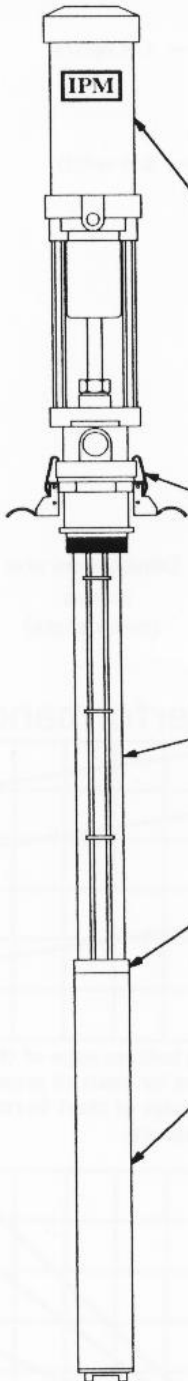

- Stainless steel construction for corrosion resistance
- Teflon® packings and Viton® seals for material compatibility

Large air motor and lower assembly provide 2 1/2 times the flow of transfer based 2:1 pumps

Quick release bung bushing allows fast slip in/slip-out drum change. No need to disconnect hoses and rotate pump. Sealed design provides moisture barrier.

"Tie-Tube" design allows above-the-drum fluid outlet with immersed lower pump.

Full length wet cup prevents material from hardening on rod stroke area while changing drums. Extends seal life.

Immersed lower pump assembly maintains wetted rod and seal area, preventing material from hardening. Extends rod and seal life.

### Typical Fluids Handled

- Isocyanates
- Polyols
- Enamels
- Waterbornes
- Acid Catalyzed Finishes

### Typical Applications

- Aerospace
- Wood Furniture
- Automotive
- Transportation
- Sporting Goods



International Pump Manufacturing 25424 74th Ave. So. Kent, WA 98032  
Phone: 253-859-3882 FAX: 253-859-3536

# 200 Series 2:1 Air Operated Fluid Pump



Immersed Lower Design

## Technical Specifications

Fluid Ratio.....	2:1
Maximum Output Flow (intermittent).....	7.5 gpm (28.4 lpm)
Maximum Output Flow (continuous).....	5.0 gpm (18.9 lpm)
Maximum Output Pressure.....	360 psi (24.8 bar)
Maximum Air Input Pressure .....	180 psi (12.4 bar)
Air Inlet Port.....	1/4 npt(f)
Fluid Outlet Port.....	3/4 npt(f)
Rod & Piston Packings.....	Teflon®
Other Seals.....	Viton®
Rod & Cylinder.....	Stainless Steel
Other Wetted Parts.....	Stainless Steel
Weight.....	24 lbs. (11.8 Kg.)

## Dimensions

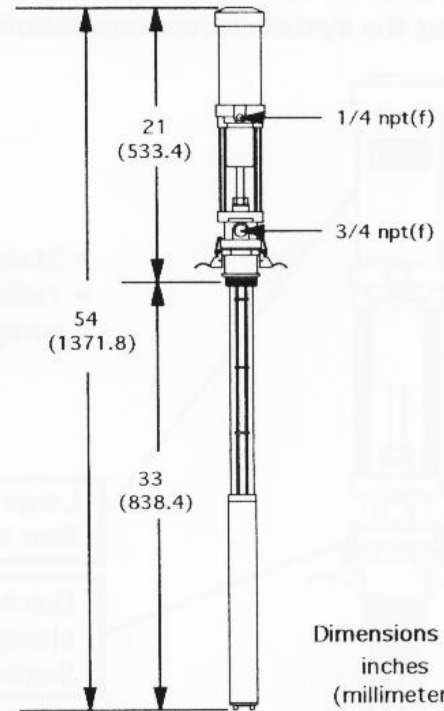

Dimensions are:  
inches  
(millimeters)

## Performance

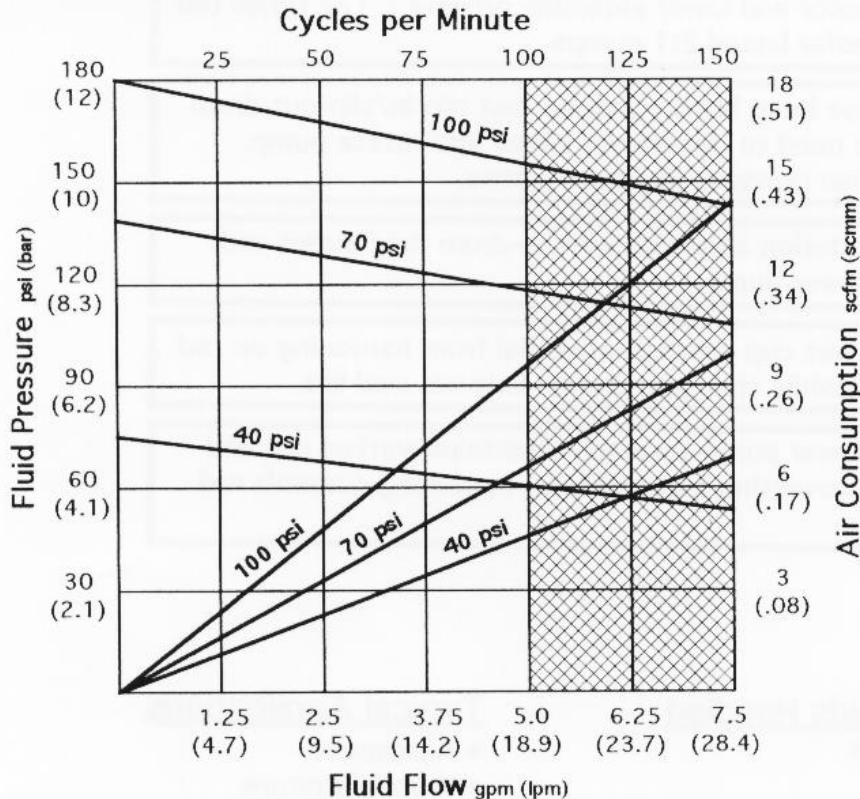

## How to Read Performance

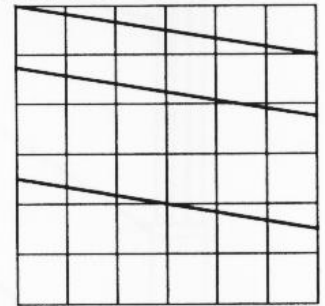

### Pressure/Flow

1. Locate required flow along bottom edge of chart.
2. Follow vertically to bold line for input air pressure.
3. Follow horizontally to left edge of chart to read maximum available fluid pressure.

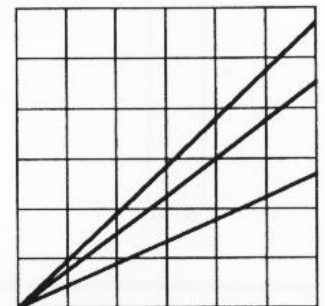

### Air Consumption

1. Locate fluid flow along bottom edge of chart.
2. Follow vertically to bold line for input air pressure.
3. Follow horizontally to right edge of chart to read air consumption.

## Model Numbers

Bare Pump Model Number: # OP 232 C  
Bung Adapter: #OP 233 A\*

\*One supplied with pump. Additional adapters can be used in new material drums for minimal interruption of operation during drum change-over. Adapters have internal seal to allow nitrogen charge or prevent moisture contamination. Toggle clamps provide quick slip-out/slip-in pump changes.